

Version: 03	EN
Date of issue: 27.5.2020	
Code: M_22_V03_EN_2020_05	



GUIDE ON CONTROLLING

Duplexvent ventilation units equipped with control system RD5

Contents

Contents	2
1 Controller CP Touch	3
1.1 Controller description:	3
1.2 Installation	3
1.2.1 Connecting the controller to unit.....	4
1.3 Controller description and functions	5
1.4 Starting the display	5
1.5 Symbols and their meaning	6
1.5.1 Symbols on the main screen	6
1.5.2 Navigation symbols	7
1.5.3 Symbols fixed on the main screen	7
1.6 Blocks on the main screen	7
1.6.1 "Power" block	7
1.6.2 "Mode" block.....	8
1.6.2.1 List of modes	8
1.6.3 "Temperature" block	8
1.6.4 "Zone" block	9
1.7 User settings	9
1.7.1 Parameters	9
1.7.2 Control settings	10
1.7.3 Holiday/Party	12
1.7.4 Weekly program setting.....	12
1.7.5 Network setting.....	14
1.7.6 Texts	14
1.7.7 Display settings	14
1.7.8 SW information (unit type, configuration, specifications, version)	15
1.8 Filter replacement indication	15
1.9 Table of alarms and notifications.....	15
1.10 Other functions.....	17
1.10.1 Forgetful operator	17
1.10.2 Bypass dampers	17
1.10.3 Circulation damper.....	17
2 Controller CP 10 RT	18
2.1 Controller CP 10 RT.....	18
2.2 Control system RD5 with controller CP 10 RT	18
3 Connecting to the unit from computer	19
3.1 Connecting the unit with a computer directly	19
3.2 Accessing the unit in local network	20
3.3 Access to the unit over the internet.....	21
3.3.1 Connecting the unit by a new user	21
3.3.2 Access to the unit by registered user:	23
4 Sending email reports	24
Annex No. 1 Problem solving: cannot connect to the unit over the internet	26

1 Controller CP Touch

1.1 Controller description:

The CP Touch controller can be connected to DUPLEXVENT units fitted with an RD5 control board. The CP Touch provides full control of these units, i.e. service parameter settings (password protected) as well as user settings. It has a manual mode, allowing the user to choose directly the operating mode of the unit, and a weekly mode controlling the unit according to a weekly program. The software version is also shown in the user setting of the controller (1.7.8).

! Note: The CP Touch controller's commissioning and connection to DUPLEXVENT units may only be done by a specialist company with up-to-date training certification for DUPLEXVENT units with RD5 controls.

1.2 Installation

First, mount the controller on the designated location on the wall.
It can be mounted on a standard electrical box with a hole spacing of 68mm.

Step 1: Before the installation dismantle the controller, removing its front from its back.



Press here

Step 2: Place the back on the designated spot on the wall and fix it using screws.



The box can be clipped on from one direction only

Step 3: Clip the front with display onto the fixed back.

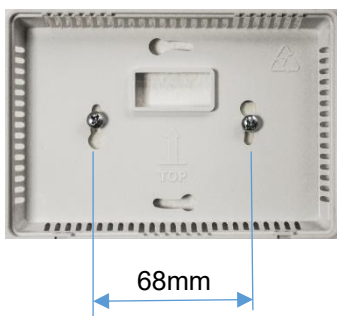

Cross-section of the wall with the controller box

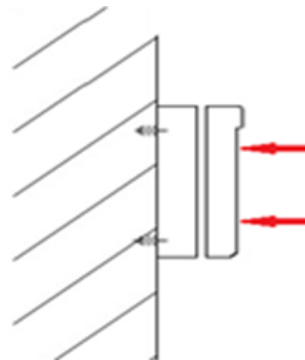

Step 4: Controller mounted on the wall.

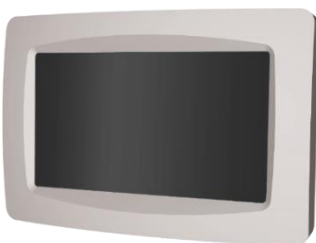

! The CP Touch must not be connected or disconnected when the unit is connected to power supply.

1.2.1 Connecting the controller to the unit

! For the controller's electrical connection follow the wiring diagram located in the lid of the AHU's cabinet.

If there are more controllers connected, they must be in a series as shown in Picture 1. Max cable length between the last connected CP touch controller and AHU unit is 50m.

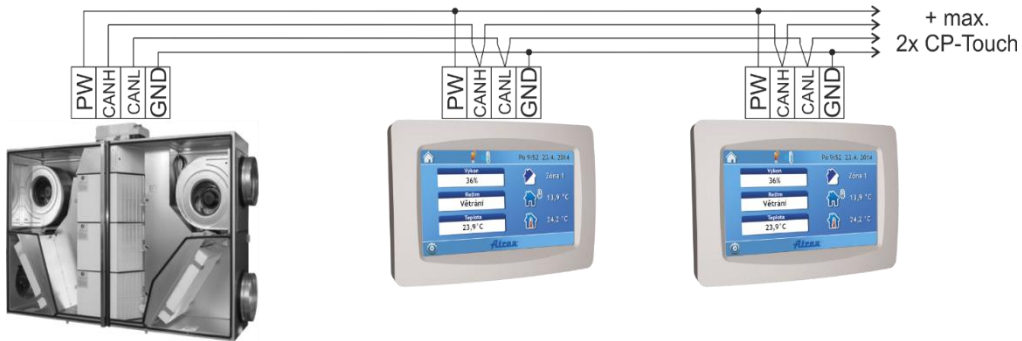

Picture 1

Up to four controllers can be connected to a unit with RD5 controls by following the diagram. The last controller on the bus bar must have a termination resistor activated – jumper short circuit, see Pic. 2.

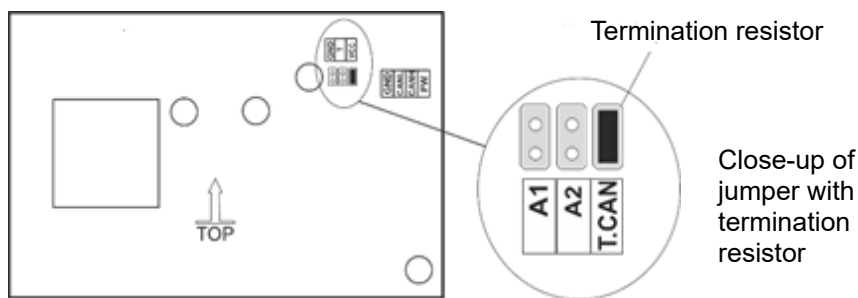

Picture 2: view of the CP Touch board

There are three jumpers located at the back of the controller board, as shown in Picture 2:

- T.CAN – A termination resistor jumper; the jumper must be fitted on the last controller in line.
- A1 – 1. Controller addressing jumper
- A2 – 2. Controller addressing jumper

The jumpers of each controller on the same bus bar must have a different address.

Table 1 shows controller connection options. When more controllers are installed, their addressing must be different. The last controller in the series must be terminated with a T.CAN jumper.

Number of controllers connected	A1	A2	T.CAN
1	0	0	✓
1	0	0	0
2	✓	0	✓

1	0	0	0
2	✓	0	0
3	0	✓	✓

1	0	0	0
2	✓	0	0
3	0	✓	0
4	✓	✓	✓

Table 1

0 Unconnected jumper
 ✓ Connected jumper

1.3 Controller description and functions



Turn on the light of a connected controller by clicking on the dark screen.

The CP Touch controller can be connected to DUPLEXVENT units fitted with an RD5 control board. The CP Touch provides full control of these units, i.e. user and service parameter settings, protected by a password.

The controller enables:

- A manual mode, allowing the user to choose directly the operating mode of the unit.
- A weekly mode to control the unit according to a weekly program.

1.4 Starting the display

After switching the CP Touch on, a starting screen appears with additional information on the status of communication with the unit.

Text/Status	Controller operation
Waiting for status	Controller is looking for application in its memory – it takes approximately 10 s.
Loading application	Loading of the application in the controller, which takes up to 10 s. The controller screen may darken for several seconds.
Downloading application	An updated version of the application is being downloaded from the control board; this may take approximately 4 minutes.
Waiting for connection	The controller is waiting for communication with the control board; if this takes more than 3 minutes, the screen switches to “Communication Error”.
Main screen appears, but data are “0”	The controller’s application has loaded properly, but communication with AHU controls is not available yet. This status may appear after switching the unit’s power supply ON when the control module application has not been launched yet. It should not last longer than 1 minute.
Communication error	Communication between the controller and the unit has not been established. A new attempt to connect is made after restarting power supply.

Main screen:

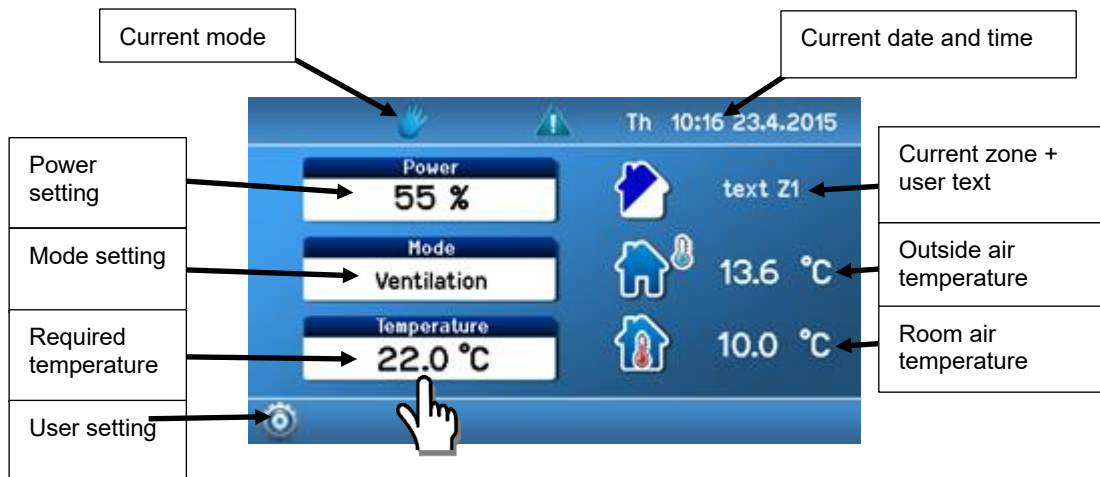

Picture 3: Main screen of the controller

To adjust parameters on the main screen, click on a parameter, see Picture 3.

1.5 Symbols and their meaning

Symbols of available settings; one of the symbols is always displayed

1.5.1 Symbols on the main screen









Group 1		Manual control of the unit
Group 2	 	Unit control according to a weekly program Temporary manual change of the weekly program
Group 3	 	Party/Holiday mode active Bank holiday mode active
Group 4	 	Symbol appears when unit is heating Symbol appears when unit is cooling
Group 5	 	Active alarm symbol (yellow) 📖 1.9 Active notification symbol (blue) 📖 1.9

Table 2

1.5.2 Navigation symbols



	Clicking returns the screen one level back
	Clicking returns the screen to the main screen
	Current language icon; clicking on the flag shows the page with language settings

Table 3

1.5.3 Symbols fixed on the main screen





 13,9 °C	Next to this symbol, outside air temperature T-ODA is shown
 24,2 °C	If extraction / room temperature control is used, interior temperature T-IDA is shown (room or extraction air temperature)
 23,7°C	If supply air temperature control is used, supply air temperature T-SUP is shown
	User interface access icon
	Service settings accessible after entering a password; any data in the service settings may be edited only by an authorized service technician.

Table 4

1.6 Blocks on the main screen

1.6.1 “Power” block

It shows the unit’s current power at the time in % or m³/h according to the configuration of the unit.

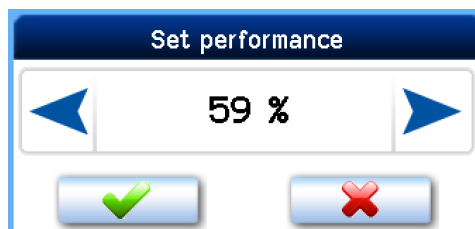

Picture 4: Configuration of power

The current power level value may not correspond to the value set manually or in the weekly program. If that is the case, the required power level is generated by a closed input or a connected sensor such as that of CO₂ concentration.

1.6.2 “Mode” block

It shows a mode current at the time, with options as provided by the unit’s configuration.

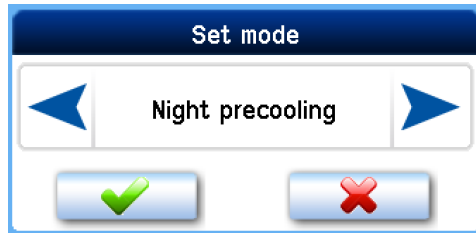

Picture 5: Configuration of mode

The current mode parameter may not correspond to the parameter set manually or in the weekly program. If that is the case, the power level required is generated by a closed input D1 - D4 or one of the inputs IN1 - INk4/2.

1.6.2.1 List of modes (defined by the type and configuration of the unit)

OFF – The unit is switched off.

Automatic - The unit is in “OFF” mode. It is started by the periodic ventilation timer or when input status changes (Dn, INk).

Ventilation – The unit is ventilating at a power level set or higher as set by an external input which is active.

Night pre-cooling – The unit is in “OFF” mode. It starts ventilation if temperature in the room is higher than the required temperature and outside air temperature is lower than room temperature.

! The night pre-cooling function requires that the following conditions are met:

1. $T(\text{IDA}) // T(\text{ETA}) - T(\text{ODA}) \geq 5,3^{\circ}\text{C}$, i.e. outdoor temperature must be by at least $5,3^{\circ}\text{C}$ lower than the room temperature or temperature of the extracted air;
2. A power of unit higher than zero must be set, be it in the manual mode or weekly schedule.

Disbalance - M-SUP and M-ETA fans are controlled according to the required fan power level and the value of the required M-SUP correction parameter. It depends on the correction setting, which remains unchanged.

Circulation – The unit circulates air in the room. It heats and cools as required.

1.6.3 “Temperature” block

It displays current temperature in °C.

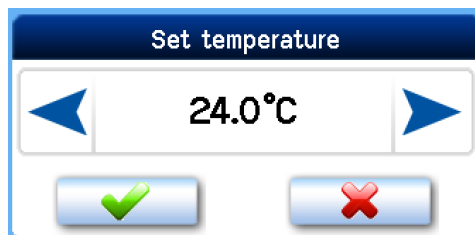

Picture 6: Configuration of temperature

The current temperature level value may not correspond to the value set manually or in the weekly program. If that is the case, the temperature required is generated by a closed input D1 – D4 and parameters set for one of these inputs if a specific temperature for Dn inputs is set.

1.6.4 “Zone” block

It displays a ventilation zone required at the time.

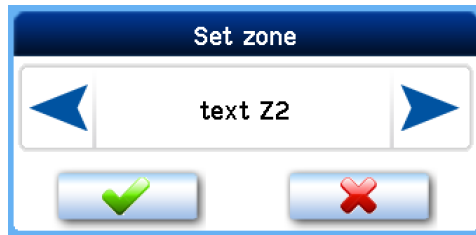

Picture 7: Configuration of zone

! Zone ventilation is set by clicking on the Zone icon  on the main screen.

The zone requirement current at the time may not correspond to the value set manually or in the weekly program. If that is the case, the zone requirement is generated by a closed input D1 – D4 and parameters set for one of these inputs.

Note

Zone texts can be set, for more information see  1.7.6. The initial zone description setting is: Text Z1 / Text Z2 / Text Z1+Z2.

Symbol of active ventilation zone with captions:

 – active zone 1,  – active zone 2,  – active zones 1+2

1.7 User settings

By pressing the button  on the main screen user setting options are displayed on the main screen.

1.7.1 Parameters

The “Parameters” options allow choosing operating parameters, setting the HS / NHS parameters and setting automatic switching between HS and NHS.

1.7.1.1 Control

“Manual” – The operating modes of the unit are selected directly by the user.

“Weekly program” – The unit is controlled according to the weekly program.

1.7.1.2 Switching between HS/NHS

This allows setting the heating or non-heating season or automatic switching between them.

“HS“ Heating season; supply air heating or room heating is allowed.

“NHS“ Non-heating season; supply air cooling or room cooling is allowed.

“T ODA-“ Automatic switching between HS/NHS based on outside temperature. The switch-over value is set by parameter “Temperature HS/NHS“ ( 1.7.1.3). If outside temperature is higher than Temperature HS/NHS, the Non-heating season is selected automatically. If outside temperature is lower than Temperature HS/NHS, the Heating season is selected automatically.

“T ODA+“ Automatic switching between HS/NHS based on outside temperature and a ratio between required and room temperatures. The switch-over value is set by parameter “Temperature HS/NHS“.

Note

- If outside temperature is higher than Temperature HS / NHS, the Non-heating season is selected automatically.
- If outside temperature is lower than Temperature HS/NHS and at the same time room temperature is higher than the required temperature by more than 5°C, the NHS remains active until outside temperature drops below 0°C.
- If outside temperature is lower than 0°C, the HS is always set automatically.

1.7.1.3 HS / NHS temperature

An outside air temperature level for automatic switching between the HS and NHS.

1.7.1.4 Current season

Indication of a season currently selected – HS or NHS. This parameter cannot be changed, it provides information only.

1.7.2 Control settings

Settings in this chapter describe the conditions of ventilation operation by the AHU.

1.7.2.1 Blocking input IN1 (No / HS / NHS)

The effect of input IN1 on the ventilation unit's operation may be limited according to the season currently selected at the time.

“No“ The IN1 input is always effective.

“NHS“ The effect of input IN1 on the unit's operation is blocked during the Non-heating season.

“HS“ The effect of the IN1 input on the unit's operation is blocked during the Heating season.

1.7.2.2 Blocking input IN2 (No / HS / NHS)

The effect of analogue input IN2 on the ventilation unit's operation may be limited according to the season currently selected at the time.

“No“ The IN2 input is always effective.

“NHS“ The effect of input IN2 on the unit's operation is blocked during the Non-heating season.

“HS“ The effect of the IN2 input on the unit's operation is blocked during the Heating season.

1.7.2.3 Heating hysteresis

To set a temperature difference compared to the temperature required to start heating. The setting range is between 0.1 °C and 5 °C (0.1 °C steps).

1.7.2.4 Cooling hysteresis

To set a temperature difference compared to the temperature required to start cooling. The setting range is between 0.1 °C and 5 °C (0.1 °C steps).

1.7.2.5 Bank holidays

Settings as per user requirements; up to sixteen different dates can be set.

Steps for bank holiday settings:

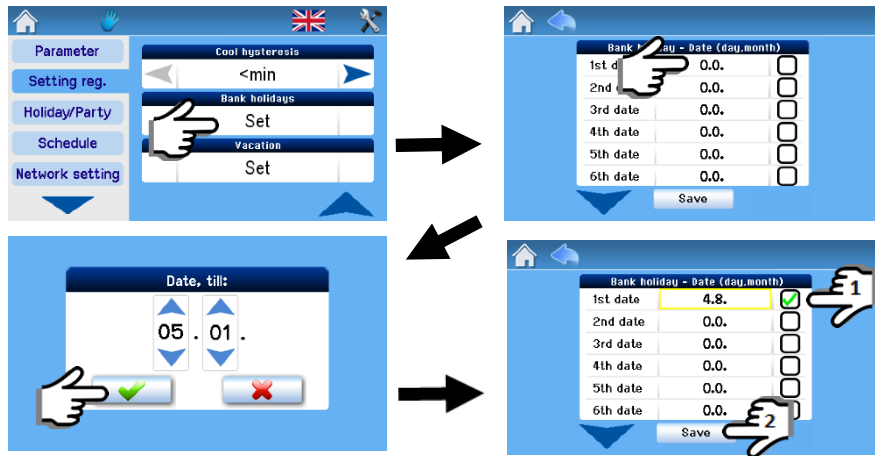

Picture 8: Configuration of holiday period



The AHU unit is controlled according to bank holiday settings when:

- The unit is in weekly program control mode
- There is a bank or school holiday on the day current at the time
- The bank holiday (school holiday) date is ticked in the holiday settings

1.7.2.6 Vacations

Settings as per user requirements; up to four different holiday periods can be set.

Steps for setting up vacation period:

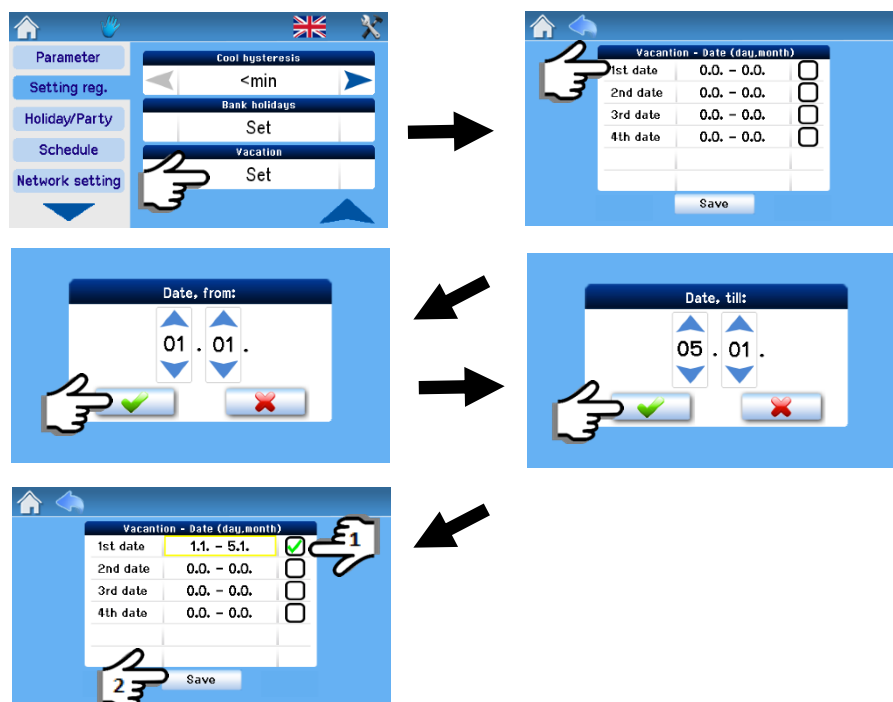

Picture 9: Configuration of school holiday period

1.7.3 Holiday/Party

This is a mode set for a limited period of time during which the unit's operation is other than in regular modes, such as when the unit is normally run according to the weekly program and should be switched temporarily to economy mode for example for a week when there is no occupancy in the house.

When the parameters set for the Holiday / Party function have been stored, the unit is activated for operation according to these parameters; these cannot be subsequently modified or the unit's operation mode changed until the period set expires or the Holiday / Party function is deactivated manually (Deactivation button).

The settings below apply when the Holiday / Party mode has been activated.

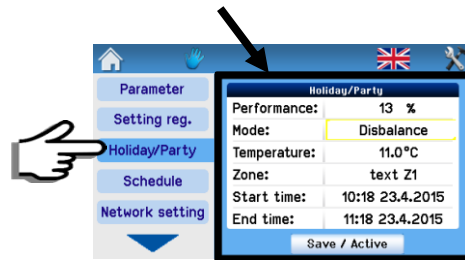

Picture 10: Configuration of mode Holiday / Party

Power: For Power settings see 1.6.1.

Mode: For Mode settings see 1.6.2.

Temperature: For Temperature settings see 1.6.3.

Zone: For Zone settings see 1.6.4.

Start time: The starting time of the mode may be delayed; the Holiday / Party mode starts according to the start time set.

End time: The Holiday / Party mode ends according to the end time set.

“Store / Activate” mode button: It serves for storing the parameters set. The mode is activated and deactivated according to the start and end times set. (After pressing, this button changes to the “Deactivate” button).

1.7.4 Weekly program setting

The weekly program is set separately for the heating and non-heating season.

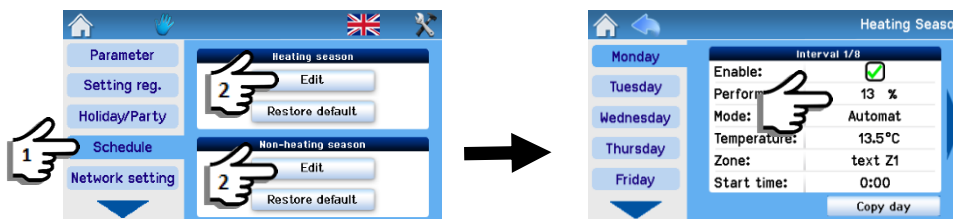

Picture 11: Configuration of weekly program

1.7.4.1 Day copying

Settings may be copied between days as shown below:

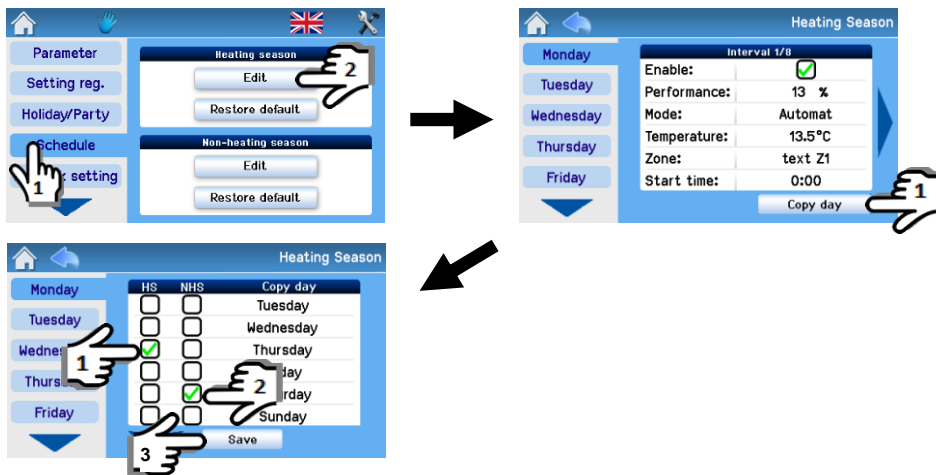

Picture 12: Copying settings between days

Example of copying: When copying, first check Thursday in HS (1) and then Saturday in NHS, (2) thereby copying all settings for Thursday in HS to Saturday in NHS.

Settings for each season provide eight intervals for each day of the week and separate settings for Bank holidays and School holidays. Each interval allows setting all operating parameters of the AHU (see 1.6.1 – 1.6.4) and the start time of the interval.

Unless the first interval of a given day starts at 00:00, the unit continues to run with parameters set by the last interval of the previous day until the first interval start time.

Use the arrows and to move between all eight intervals (days)

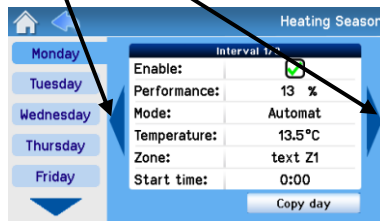

Picture 13: Moving between intervals

The weekly program allows copying and pasting the settings of a given day as follows:

- Into each day of the week
- Into selected days
- Into Bank holidays / School holidays
- Into Heating and Non-heating season days

1.7.5 Network setting

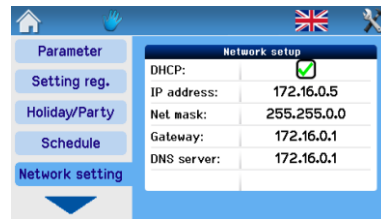

Picture 14: Network setting

DHCP: When checked, the network is automatically set from the internet; if not checked, the network must be set manually.

 The “Save” button stores the values set and also immediately restarts with new values.

1.7.6 Texts

The parameter “Texts” is used for changing adjustable texts as required. The modified text is shown in the window “Mode” if unit enters the mode that is based on such input. Default texts are: D1 - D4, IN1, IN2, Zone 1, Zone 2, Zone 1+2, INk1 - INk4, T.

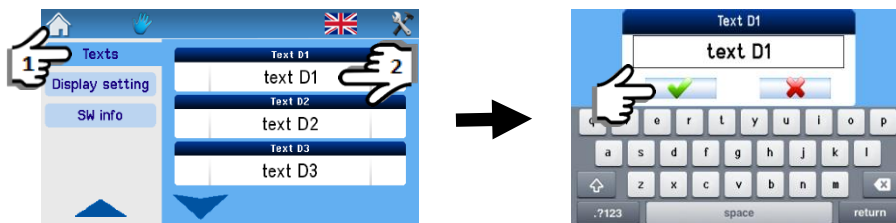



Picture 15: Change of zone names

 Texts shown by remote control and web interface are identical. For more information on local or remote access to the unit from your computer see Chapters 3 - 3.3.

1.7.7 Display settings

In this section you can set the basic parameters of the display:

Backlight setting

The display backlight is changed using the setting arrows; see Picture 16  

Internet time sync

Time sync with the internet is done by checking this option as shown in the picture 16; the update is done immediately. 

Time and date setting

The date and time are set by clicking on options shown in the Picture 16 

 In case of a power failure and loading wrong time data, it is necessary to replace the internal battery on the board RD-int.

- The type of internal power battery is CR 2032, it is placed in the control module, board RD-int.
- The battery must be replaced by a service technician.

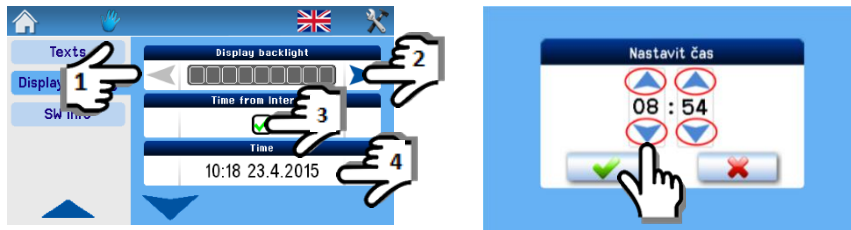

Picture 16: Configuration of time and date

1.7.7.1 Time zone setting

The time zone setting according to the location of the unit is done by the setting arrows.

1.7.7.2 Daylight saving time (summer time)

An option to switch automatically between the summer and standard time.

1.7.8 SW information (unit type, configuration, specifications, version)

Information on the type of the unit, its manufacturing number and the version of the control software.



Picture 17: Information about the unit

1.8 Filter replacement indication

In some units, the “Filter replacement” notification is also shown by the button for filter replacement confirmation (by pressing this button the date of subsequent filter replacement is saved).

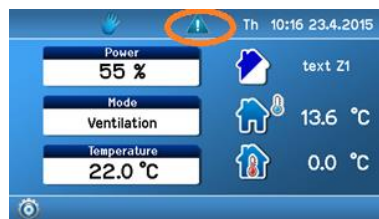

Picture 18: Notification that filter replacement is needed

1.9 Table of alarms and notifications

The messages shown in the table below provide information on irregular or unexpected events in the AHU system.

Table of alarms (yellow triangle) 

Message	Meaning	What to do?
Room temperature sensor	Failure of the room temperature sensor connected to the CP Touch controller.	Contact a service technician.
TEa temperature sensor	Communication breakdown or failure of the TEa temperature sensor.	Contact a service technician.
TEb temperature sensor	Communication breakdown or failure of the TEb temperature sensor.	Contact a service technician.

Heat recovery exchanger freezing	Frost depositing inside the heat recovery exchanger.	The air extracted from the building is likely to be very humid and the outside temperature is low. This condition usually lasts for several minutes and the unit goes back to normal operation after the heat recovery exchanger has been defrosted.
Temperature sensor downstream TA2 external heater	Communication breakdown or failure of the temperature sensor downstream the warm water or electric heater.	Contact a service technician.
1 st frost protection	Temperature downstream the heater is lower than 7.5 °C.	The unit ventilates as scheduled. AHU warm water supply opens to the maximum.
2 nd frost protection	Temperature downstream the heater is lower than 5.5 °C.	Check the source of hot water. Fans stop, AHU warm water supply opens to the maximum.
STOP circuit active	The emergency stop contact is opened.	The stop contact has been activated by a fire or other safety system; check its status.
Temperature sensor TU1	Communication breakdown or failure of the TU1 fan temperature sensor in the unit.	Contact a service technician.
Temperature sensor TU2	Communication breakdown or failure of the TU2 fan temperature sensor in the unit.	Contact a service technician.
Set orientation (applies only to DUPLEXVENT Flexi and DUPLEXVENT ECH/ECVH)	The unit's orientation is not set, i.e. it is not determined which fan is the supply fan and which fan is the extraction fan.	This parameter blocks the operation of the unit and must be set in the service menu. Contact a service technician.
Heater setting	The heater type is not set (water or electrical).	This parameter blocks the operation of the unit and must be set in the service menu. Contact a service technician.
Manometer failure	If the unit is fitted with air flow rate gauges, one of them does not measure correctly or is faulty.	Contact a service technician.
Unbalanced flow rate	The flow rate through the unit is out of balance, the fans do not work as per settings.	Contact a service technician.
AHU overheat	One of the temperature sensors has detected a temperature higher than 77 °C.	Disconnect the unit from power supply and, if there is no risk of overheating in the room (fire etc.), reconnect it.
Communication error	Breakdown of communication between the controller and AHU.	Check whether the cable between the unit and controller is not interrupted or contact a service technician.

Table 5

Table of notifications (blue triangle)

Clogged filter	The filters in the unit are clogged and do not work properly.	The filters in the unit must be replaced.
Heat recovery exchanger defrosting	Frost deposits in the heat recovery exchanger; the unit is not recovering the heat but defrosting.	The air extracted from the building is likely to be very humid and the outside temperature is low. This condition usually lasts for several minutes and the unit goes back to normal operation after the heat recovery exchanger has been defrosted.
Insufficient heating capacity of Heater 1	The heating capacity of the unit's heater is not sufficient.	Check the status of primary heating. The unit has switched to heating from its back-up source.
High tariff	The unit does not start the electric heater due to high electricity prices.	Power supply in a high tariff. Electrical heating is blocked.
Air flow rate too low	The air flow rate through the unit is not high enough.	Contact a service technician. Check the condition of filters.
"AI input" failure	The unit has not accepted an external alarm signal.	Contact a service technician.
The unit is not operational	The unit has not been commissioned by a certified technician.	Contact a service technician.

Table 6

1.10 Other functions

1.10.1 Forgetful operator

After the ventilation period set has expired, the command on the D1-D4 input will no longer be executed. This function limits the duration of the AHU running.

1.10.2 Bypass dampers

Damper for bypassing the heat recovery exchanger. DUPLEXVENT heat recovery units are optionally fitted with a heat recovery exchanger bypass. The damper can be used e.g. for pre-cooling buildings by air from the outside at night in the summer or cooling in the transitional period. This saves costs of cooling.

The bypass damper is primarily controlled by setting the required temperature T_p and cannot be controlled manually.

1.10.3 Circulation damper

The circulation damper (also known as mixing damper) is used for mixing outside air with extracted (circulated) air and it runs in modes: **On/Off**, **Eco**, **Comfort** or **In-input**.

On/Off: Circulation damper can be switched between fully open (Circulation mode) and fully closed (for instance Ventilation mode).

Eco: To reach the inlet air temperature or room temperature the circulation air is used first. Ventilation is minimized since this is connected with higher activation of heating/cooling. The main focus is the most economical operation.

Comfort: To reach the inlet air temperature or room temperature fresh outdoor air with subsequent re-heating or cooling is being used as much as possible. In comparison to Eco mode higher air quality in the ventilated area is achieved, however, at the expense of higher costs for heating or cooling.

In-input: Circulation damper is being controlled by voltage on IN1/IN2 inputs. For instance, sensor of CO₂ concentration in ventilated area can be connected to IN1/IN2. In case of lower CO₂ concentration more circulation air is being used. In case of higher CO₂ concentration more fresh air is being used.

2 Controller CP 10 RT

2.1 Controller CP 10 RT

The controller CP 10 RT enables controlling the ventilation power and supply air temperature. It is supplied to be mounted on the wall. The controller can be optionally installed on a standard wiring box with a spacing of holes 68 mm. It is advisable to install the controller on the wall at a height 1.3 to 1.5 m in an easily accessible, illuminated and dry place. Use a shielded cable (SYKFY 5 x 2 x 0.5) to make connection. On request for greater distance between the controller and the ventilation unit, the cable should be replaced/extended (maximum 25 m). The controller is to be installed by a technician of a specialised electrotechnical company.

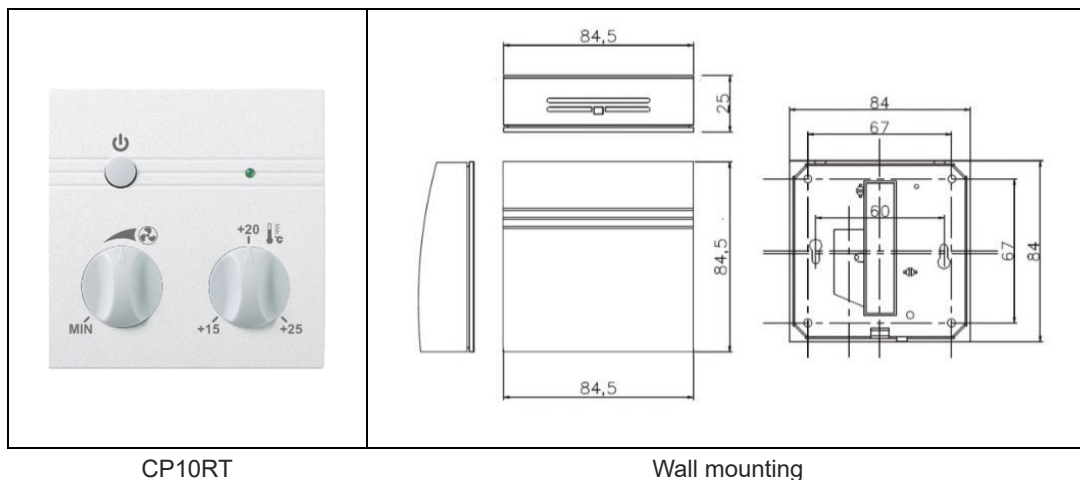

CP10RT

Wall mounting

2.2 Control system RD5 with controller CP 10 RT

The controller is used to mechanically control the performance of fan, to choose supply air temperature, to turn ON/OFF ventilation and to signalize failures. The controller can be combined with the controller CP touch, or control from a web browser, see Chapters 1 and 3.

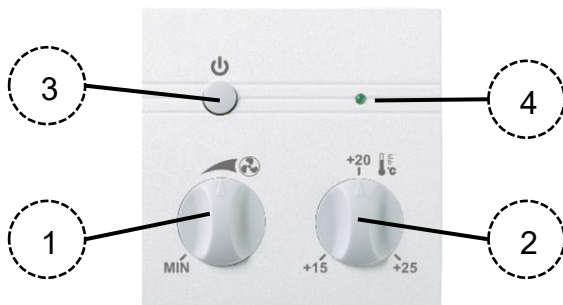

Description of controller:

- 1 - Turning knob to set the air power 20-100%
- 2 - Turning knob of inlet temperature – re-heating 15–25°C (CP 10RT 40 enables 10-40°C)
- 3 - Turn On/Off button. Button in position ON => unit is ventilating according to the set power or requirement from external signal if the requirement from external signal is higher. Button in position OFF => ventilation operation is being blocked.

- 4 - LED signalling
- Green – ON** => Air volume provided by the unit corresponds to the value set on the remote controller.
- Green – flashing** => Air volume provided by the unit is higher than the value set on the remote controller (e.g. due to active ext. signal).
- Red – ON** => System reports failure (to find the exact type of fault, connect to the unit from web browser and on the **User page** select the item **Alarms**).

3 Connecting to the unit from computer

DUPLEXVENT ventilation units equipped with control system RD5 can also be controlled using a web browser. This allows the user to do the following, either from a local network on site or through the Internet:

- Change user setting of the unit;
- Watch the unit's operational parameters including error messages;
- Browse the unit's operational history;
- Set e-mail notification with Alarm or Warning messages for up to three e-mail addresses.

3.1 Connecting the unit with a computer directly

Situation: The DUPLEXVENT unit is connected to a computer directly, using no network components.

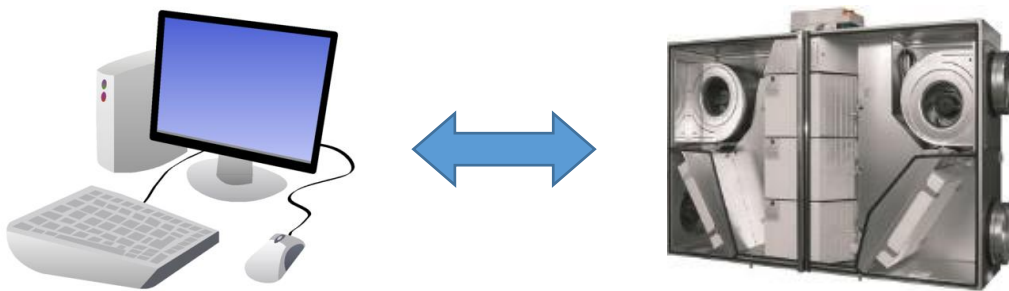

1. Connect the unit with computer by ethernet cable.
2. Set up fixed IP address in the computer

Steps in Windows 10:

- a) Select **Settings > Network and internet > Ethernet > Change adaptor options**
- b) Right-click on **Ethernet > Properties**
- c) Select **Internet Protocol version 4 (TCP/IPv4)** and click on **Properties**
- d) Select **Use the following IP address**
- e) Set up IP address of computer for communication with the unit. Copy the first three numbers from the IP address of the unit. Choose the fourth number from the range 1 to 255; the number must be different from the number already used in the IP address of the unit. You can learn the IP address of the unit on the CP-Touch controller, see Chapter 1.7.5. Default IP address of the unit is 172.20.20.20.

Example: If the address of the DUPLEXVENT unit is set to 172.20.20.20 the address of the computer must be in the range from 172.20.20.1 to 172.20.20.255 but not the address 172.20.20.20 already used by the unit.

3. In the web browser enter the IP address of the DUPLEXVENT unit;

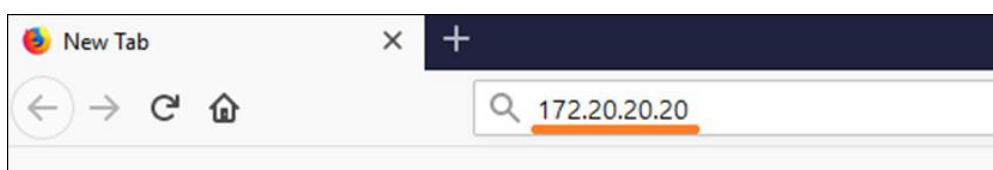

4. Enter the login password. Default password is “pass”, default administrator password is “Admin”.



Once the password is entered connection will be established.

3.2 Accessing the unit in local network

Situation: DUPLEXVENT unit and computer are connected in one local network. IP addresses of both devices have been assigned by a router. Or both devices have fixed IP address, based on rules of the local network.

! Ethernet connector RJ45 must not be connected to the Ethernet network operated with PoE (Power over Ethernet).

1. Find out the IP address of the unit. On the main screen of the CP-Touch controller click on the **Settings** symbol in the bottom left corner and select **Network setting** (see Chapter 1.7.5). Local admin can also provide you with the IP address.

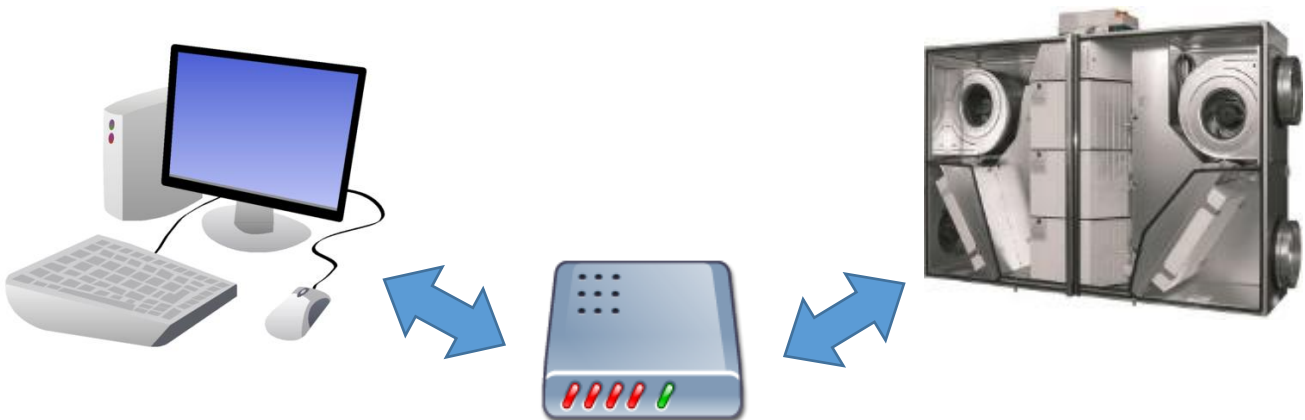

2. In the web browser enter the IP address of the DUPLEXVENT unit (e.g. 192.168.10.15).

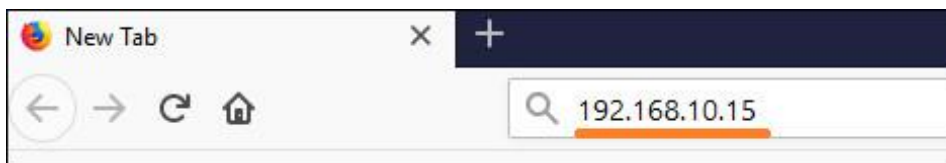

3. Enter the password. Default password is “pass”, default administrator password is “Admin”.

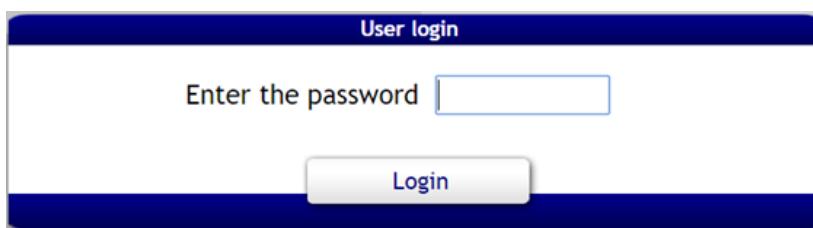

Once the password is entered connection will be established.

3.3 Access to the unit over the internet

Situation: DUPLEXVENT unit is connected to a local network which is connected to internet. Computer from which you connect to the unit is also connected to the internet but in a different network. Remote connection is provided by a service called Connect server¹ (<https://airflowmvrcontrols.com>).

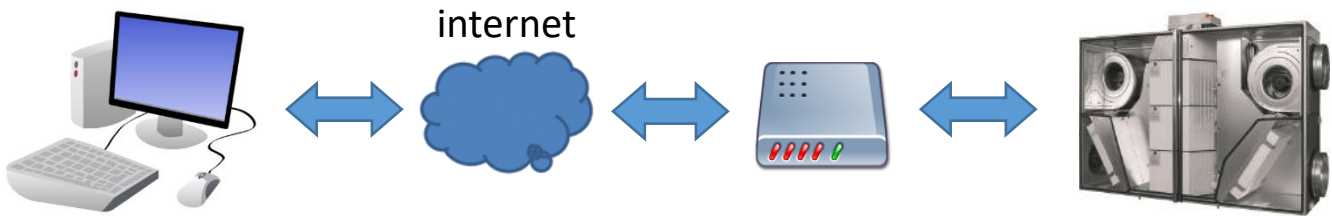

- ! • Ethernet connector RJ45 must not be connected to the Ethernet network operated with PoE (Power over Ethernet).
- ! • If the unit is connected to a computer network from which the Internet can be accessed, the factory settings allow the unit to communicate within the Connect server service, which means that the unit's operation and status data will be regularly sent to the server dedicated to remote control of the unit outside of the local network where the unit is connected. The data being sent do not contain any personal details of the owner or user of the unit. The user can deactivate and reactivate this communication any time in the user settings.

3.3.1 Connecting the unit by a new user

1. Connect the computer from which you will be connecting to the unit to internet.
2. Connect the DUPLEXVENT unit into local network from which internet is available;
3. Assign IP address to the DUPLEXVENT unit in the local network; the IP address should correspond with the respective local network;
4. Enter the address <https://airflowmvrcontrols.com> in a web browser.
5. Choose a (New in here?) **Register now** and fill in the registration form and click on **Register**:

The screenshot shows a web form titled 'CONNECT SERVER' with a language selector 'EN'. The form contains four input fields: a username field with 'john', a password field with masked characters and an eye icon, an email field with 'john.doe@atrea.cz', and a registration code field with '101020203030'. A blue 'Register' button is at the bottom.

¹ During normal operation of the unit the volume of data transferred does not exceed 10MB a month.

- a. **User name** - fill in any user name; this will serve to connect to the unit after its registration is completed.
- b. **Password** – choose any password. You will use the password to connect to the unit once its registration is completed (we recommend choosing stronger password. Small / capital letters are distinguished).
- c. **Email** – you can configure the unit to send you various kinds of information (e.g. warnings, alarms).
- d. **Registration number** – copy the number from the form supplied along with the unit (example mentioned below: 10658299411). Registration number is a unique code of each DUPLEXVENT unit that authorizes the user to access the unit.

Z26002-000	
DUPLEX HVAC unit	Prod.No.: M651602
 Reg.No.: 10658299411	

6. Press the **Register** button. A message will appear

First login to the unit 📌 📄

Enter the unit password

OK
Storno

7. Enter local password of the unit. Default password is „pass“, default admin password is “Admin”. Without the password you cannot connect to the DUPLEXVENT unit even when you know the registration number (second level of protection).

 To change the local password, select **User settings > Password change**.

Once the password is confirmed you will see a window with the estimate when the connection will be established (up to 5 minutes). User web interface where you can control the unit will appear.

3.3.2 Access to the unit by registered user:

1. Follow the steps 1 to 4 from the Chapter 3.3.1
2. Login to your account:

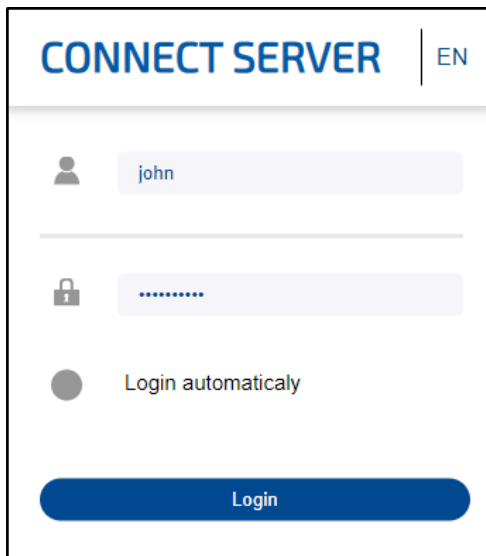

The screenshot shows the 'CONNECT SERVER' login interface. At the top left is the title 'CONNECT SERVER' and at the top right is a language selector 'EN'. Below the title is a horizontal line. There are two input fields: the first is for the username, containing the text 'john', and the second is for the password, containing a series of dots. Below the password field is a checkbox labeled 'Login automaticaly' which is currently unchecked. At the bottom of the form is a large blue button labeled 'Login'.

Connection will be established without entering local password of the unit. If the local password is different than the password stored on the **Connect server** you will be prompted to enter the correct password.

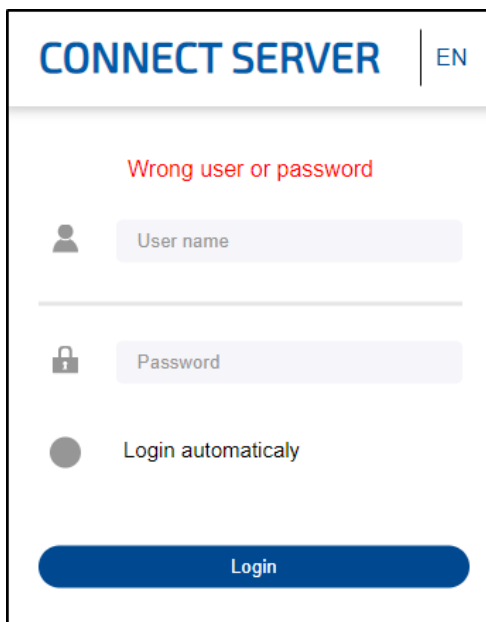

The screenshot shows the 'CONNECT SERVER' login interface after an incorrect login attempt. At the top left is the title 'CONNECT SERVER' and at the top right is a language selector 'EN'. Below the title is a horizontal line. A red error message 'Wrong user or password' is displayed above the input fields. There are two input fields: the first is labeled 'User name' and the second is labeled 'Password'. Below the password field is a checkbox labeled 'Login automaticaly' which is currently unchecked. At the bottom of the form is a large blue button labeled 'Login'.

Once correct password is entered connection will be established.

4 Sending email reports

When alarm or warning occurs in a DUPLEXVENT unit equipped by control system RD5, connect server can inform you by email report. Emails can be sent up to 3 different email addresses. Communication with Connect server must be set up so that email reports can be sent to the user.

1. Open the website of the service Connect server at <https://airflowmvrcontrols.com>;
2. Login to your user account;
3. Select the icon „User setting“



4. By choosing **Language** set a language of messages that will be sent. Clicking on the button marked with symbol "+" add the required email address.

The screenshot shows the "Edit record - Users" window. On the left, there are fields for "User name", "Fullname" (John Doe), "Email" (john_doe@airflow.com), "Password", and "Language" (English). Below these is an "Emails" section with a list of email addresses, one of which is "john_doe@airflow.com". On the right, there is a "Send email" section with a "Reset to default" button and a list of "Warnings" and "Alarms" that can be selected for email notification. The list includes items like "Heat Exchanger frost", "Heat exchanger defrosting", "Higher tariff", "Insufficient volume flow", "Insufficient power of the primary heater", "The air filter is choked", "Input alarm - IN1", "Input alarm - IN2", "Input alarm - INk1/1", "Input alarm - INk2/1", "Input alarm - INk3/1", "Input alarm - INk4/1", "Input alarm - INk1/2", "Input alarm - INk2/2", "Input alarm - INk3/2", "Input alarm - INk4/2", "Alternate configuration file", "Insufficient heater warm up", "Update is in progress", "Trial operation active", "Trial operation expired", "Emergency mode active", and "Heat Pump defrosting". At the bottom, there are "Save" and "Cancel" buttons.

5. Select which of the Warnings and Alarms should be sent to the email address. Save the changes.
6. Select the icon „Units“, the list of registered units will appear.

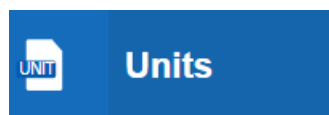

7. Select the unit from the list and by clicking the button with pencil open the setting of sending email reports.

The screenshot shows the "User units" window. At the top, there are "Connect unit" and "Close window" buttons. Below is a table with columns: "Unit title", "Status", "Product number", "Registered", "Alarm email", "Alarm email", "Alarm email", "Warn. email", and "Warn. email". The first row of data is: "Dem", "Disconnects", "????????", "15.5.2020 10.1", and several empty cells. A yellow arrow points to a pencil icon in the top toolbar.

Unit title	Status	Product number	Registered	Alarm email	Alarm email	Alarm email	Warn. email	Warn. email
Dem	Disconnects	????????	15.5.2020 10.1					

8. In column „Alarm emails“ or „Warning emails“ select email addresses to which Alarms or Warnings should be reported.

The screenshot shows a web form titled "New record - User units". At the top right, there is a "Status" dropdown menu set to "OK". Below this are four input fields: "Unit title" containing "Demo", "Product number", "Registration number", and "Unit password". The form is divided into two columns: "Alarm emails" and "Warning emails". Each column contains three dropdown menus. The first dropdown in each column is selected and shows the email address "john_doe@airflow.com". The other two dropdowns in each column show a hyphen "-" as a placeholder. At the bottom of the form, there are two buttons: "Save" and "Cancel".

Annex No. 1 Problem solving: cannot connect to the unit over the internet

Make sure that the following steps have been done:

1. Computer from which you access the unit is connected to the internet;
2. DUPLEXVENT unit is connected to local network from which internet is available;
3. DUPLEXVENT unit is correctly configured in the local network (IP address of the unit is set up according to the local network);
4. The service „Connect server“ is enabled.
 - a. Connect to the unit locally, follow the Chapters 3.1 or 3.2.
 - b. On default screen select **User settings > Communication > “Connect server“ function > On.**

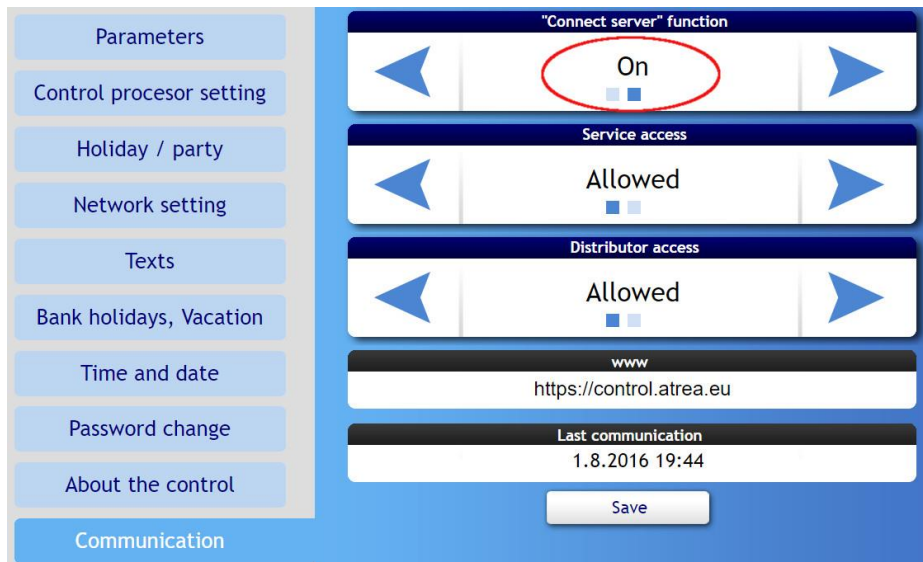

5. Make sure that the period of regular “pings” from the unit to the Connect server is configured.
 - a. Select **Service setting** in the bottom right corner
 - b. Select **Settings** and fill in password. Service partners and installers who have attended Airflow training know the password.
 - c. Select **Maintenance (3.15)**. Make sure that the **Refresh period length (3.15.6)** is set to 5 minutes.

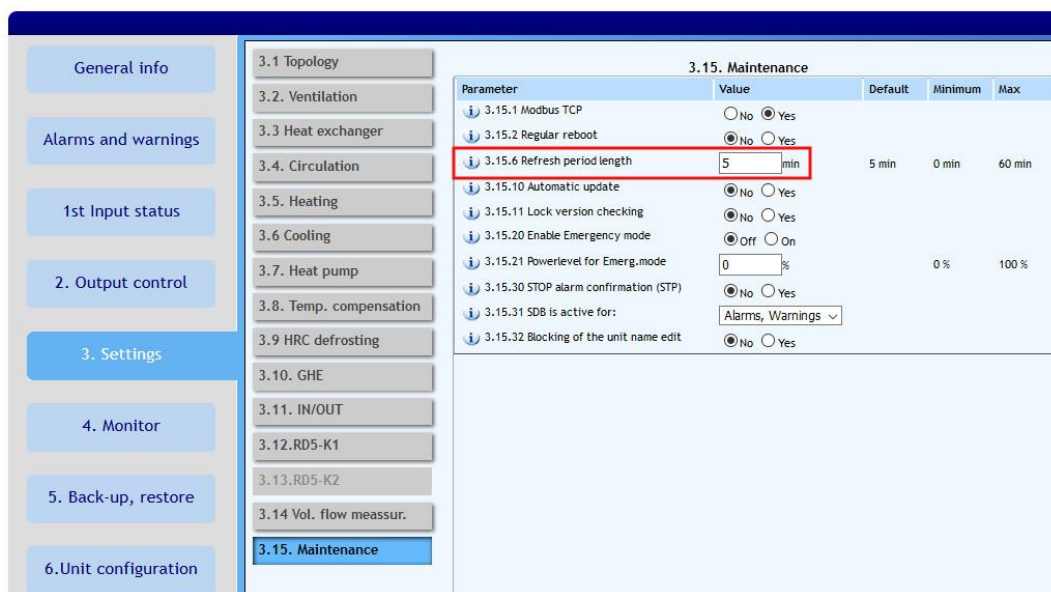

Now try connecting to the unit over the internet once more, follow the Chapter 3.3.

Notes

.....
.....
.....
.....
.....
.....
.....
.....
.....
.....
.....
.....
.....
.....
.....
.....
.....
.....
.....
.....
.....
.....
.....
.....
.....
.....
.....
.....
.....
.....
.....
.....
.....
.....
.....
.....
.....
.....
.....
.....
.....
.....
.....
.....
.....
.....



Call: 01494 525252 **Visit: airflow.com**



Airflow Developments Limited
Aidelle House, Lancaster Road,
Cressex Business Park,
High Wycombe, Buckinghamshire,
United Kingdom, HP12 3QP

E-mail: info@airflow.com
Telephone: +44 (0) 1494 525252
airflow.com

80001182 Issue 1 04/22

© Airflow Developments Limited, Airflow Developments Limited reserve the right, in the interests of continuous development, to alter specifications without prior notice. All orders are accepted subject to our conditions of sale which are available on request



04/22/01/01 14/01/21/01 04/22/01/01 04/22/01/01